

# FAST HIGH VOLTAGE TRANSISTOR SWITCHES

This new generation of BEHLKE high voltage switching modules utilize an advanced MOSFET technology with very low on-resistance, the so called Trench FET technology. The switching speed of those modern FET is slightly slower than that of a classical power FET, but is still much faster than that of any IGBT, which is preferably used to achieve low turn-on losses. The new MOSFET switches of series HTS-B combine very low dynamic switching losses with moderate turn-on losses and are a serious alternative to IGBT switches. Another important advantage compared to the fault sensitive IGBT is the positive temperature coefficient of the on-resistance, which makes the switch short circuit proof within the thermal limits. Furthermore overvoltage transients as well as voltage reversal respectively current reversal is less dangerous to MOSFET's than to IGBT's. Insofar these switching modules are well suitable for applications with high demands on operational safety even under worst conditions.

The switching modules incorporate all features of the well known HTS switch family: Easy handling, high reliability, low jitter and reproducible switching behaviour.

The switch is turned on by a positive going signal of 3 to 6 volts amplitude, provided the auxiliary power supply is permanently connected to the +5.00 VDC input. The on-time may simply be varied between 120 ns and infinity by the input control pulse width. An interference-proof driver circuit provides signal conditioning, auxiliary voltage monitoring, frequency limitation and temperature protection. In case of any false operating condition the switches turn off immediately and a fault signal is generated (TTL level). The high frequency burst operation (>10 pulses/100µs) requires the option HFB (connection of external buffer capacitors at the driver). For operation at higher frequencies than specified under  $f_{(max)}$  the option HFS must be used. In that case an internal DC/DC converter must be supported by an external supply of +90 VDC (± 5%, approx. 2-10 Watts depending on switching frequency).

Due to the high galvanic isolation the switches may simply be operated also in floating set-up's or in high-side circuits. Several housing options are available to meet individual constructional and power requirements. The standard plastic housing is used in low frequency applications with low average power dissipation. The plastic modules can additionally be fitted with non-isolated cooling fins (available as options CF, CF-X2 and CF-X3), which improves the max. Continuous Power Dissipation  $P_{d(max)}$  by approx. factor 10 with forced air (>4m/s) or by factor 50, if the switching modules are immersed in isolating cooling liquids (e.g. GALDEN HT200, flow rate >0.1m/s, standard cooling fins). Another cooling method is given by the use of the grounded cooling flange (option GCF and GCF-X2). In conjunction with an optional water cooling plate or any other high performance heatsink, maximum power dissipations in the range of 0.5 to 1.5 kW are possible, with customized cooling flanges even up to 2.5 kW.

The modules can be installed on a printed circuit board, but if operated under air conditions, the use of option PT-HV (pigtails for HV connection) is recommended, in order to ensure a sufficient creepage distance according to industrial standards. For detailed design recommendations please refer to the general instructions for use.

**HTS 31-12-B** 3 kV / 125 A  
**HTS 61-12-B** 6 kV / 125 A

**MOSFET TECHNOLOGY**

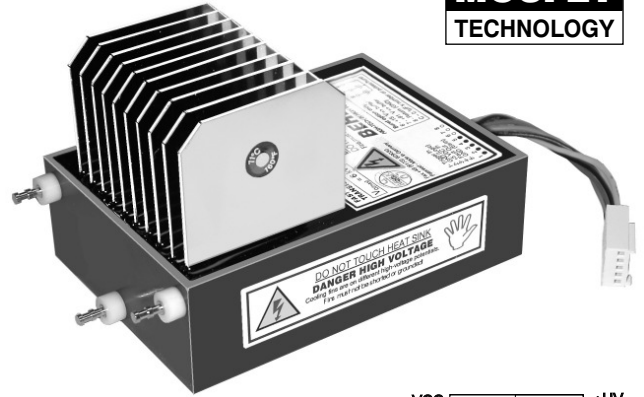

**HTS 61-12-B**  
 with option CF - Patented -  
 Made in Germany

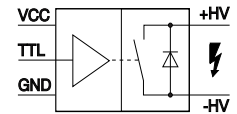

**Variable On-Time**  
**Very Low On-Resistance**

## Test Circuit (High-Side Switch)

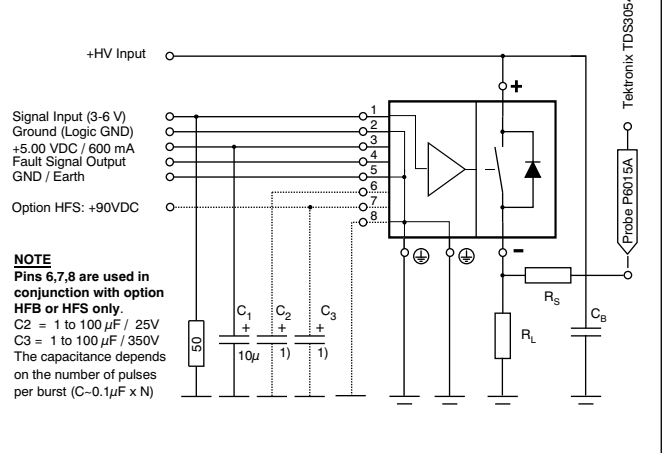

## Basic Circuits

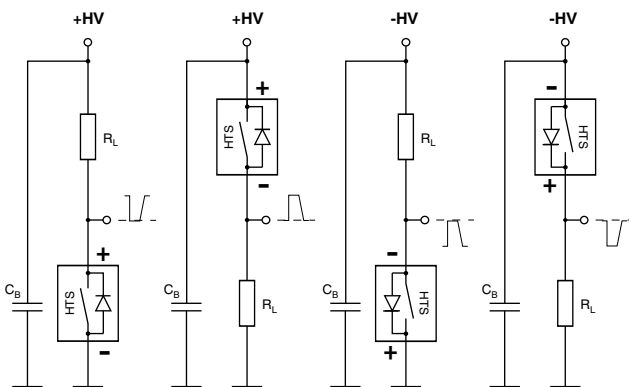

## Important EMC Design Hints

- Keep the wiring as short as possible and avoid large induction loop areas of the peak current carrying lines; the forward and return lines should be installed as closely as possible together. **Control and power circuit must not be mixed. Always keep the transformer principle in mind!**
- Use shielded leads at the control side to minimize noise induction. Low impedance drivers with 5 Volt output swing (into 50 Ohm) are required for driving long pulse transmission lines. Signal transmission lines must be terminated properly (e.g. by 50 Ohm). The auxiliary power supply must be well decoupled by a sufficient buffer capacitor.
- This high speed switching module can generate extreme di/dt's and dv/dt's. Therefore it is not useful to operate the switch and its peripheral components without a shielded housing. Other electronics including power supplies (!) may be disturbed. Please note your local EMC / EMI regulations. Please also see our option offers for possible EMC / EMI relevant modifications.

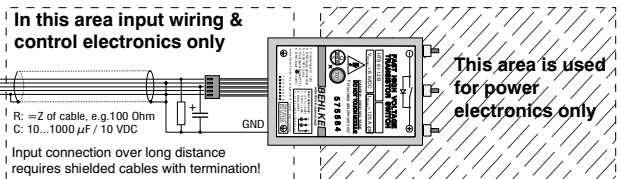

# TECHNICAL DATA

Specification	Symb.	Condition / Comment	HTS 31-12-B	HTS 61-12-B	Unit	
Maximum Operating Voltage	$V_{O(max)}$	$I_{off} < 100 \mu ADC$	3000	6000	VDC	
Minimum Operating Voltage	$V_{O(min)}$	Increased $t_{r(on)}$ and $t_{r(off)}$ below $0.1 \times V_{O(max)}$	0		VDC	
Typical Breakdown Voltage	$V_{br}$	$I_{off} > 1mADC$ , $T_{case} = 70^\circ C$	3150	6300	VDC	
Galvanic Isolation	$V_i$	Continuously		15 25 80	kVDC	
		Standard housing Option PT-HV Option ISO-80				
Maximum Peak Current	$I_{P(max)}$	$T_{case} = 25^\circ C$ $T_{fin} = 70^\circ C^*$ *measured at base	$t_p < 100 \mu s$ , duty cycle $< 1\%$ $t_p < 1 ms$ , duty cycle $< 10\%$ $t_p < 10 ms$ , duty cycle $< 10\%$	125 67 52	ADC	
Max. Continuous Load Current	$I_L$	$T_{case} = 25^\circ C$ $T_{flange} = 25^\circ C$ $T_{fin} = 70^\circ C^*$ *measured at base	Standard plastic case Option CF, fins in air $> 4m/s$ Option CF, in Galden® $> 0.1m/s$ Opt. GCF, grounded cooling flange	2.6 10 20.7 28.9	2.5 7.1 14.6 20.4	ADC
Static On-Resistance	$R_{stat}$	$T_{case} = 25^\circ C$	$0.1 \times I_{P(max)}$ $1.0 \times I_{P(max)}$	0.48 1.2	0.95 2.4	$\Omega$
Maximum Off-State Current	$I_{off}$	$0.8 \times V_O$ , $T_{case} = 70^\circ C$ , $< 5\mu A$ leakage optionally available		50		$\mu ADC$
Turn-On Delay Time	$t_{d(on)}$	@ $I_{P(max)}$	120	150	ns	
Typical Turn-On Rise Time	$t_{r(on)}$	$0.1 \times V_O$ , $0.1 \times I_{P(max)}$ $0.5 \times V_O$ , $0.1 \times I_{P(max)}$ $0.8 \times V_O$ , $0.1 \times I_{P(max)}$ $0.8 \times V_O$ , $1.0 \times I_{P(max)}$	10 12 15 25	11 12 17 30	ns	
Typical Turn-Off Rise Time	$t_{r(off)}$	$0.8 \times V_O$ , $0.1 \times I_{P(max)}$ , resistive load, 10-90%	50		ns	
Minimum On-Time	$t_{on(min)}$	Lower $t_{on(min)}$ on request	180		ns	
Maximum On-Time	$t_{on(max)}$	Please note possible $P_{d(max)}$ limitations	$\infty$			
Switch Recovery Time	$t_{rc}$	$t_{rc}$ = minimum pulse spacing	500		ns	
Typical Turn-On Jitter	$t_{j(on)}$	$V_{aux} / V_{tr} = 5.0 VDC$ , fixed switching frequency	300		ps	
Max. Switching Frequency	$f_{(max)}$	Pls. note possible $P_{d(max)}$ limitations	Standard Opt. HFS, please consult factory	20 100	10 100	kHz
Maximum Burst Frequency	$f_{b(max)}$	Use option HFB for $> 5$ pulses within $100 \mu s$		2	MHz	
Maximum Continuous Power Dissipation	$P_{d(max)}$	$T_{case} = 25^\circ C$ $T_{flange} = 25^\circ C$ $T_{fin} = 70^\circ C^*$ *measured at base	Standard plastic case Option CF, fins in air $> 4m/s$ Option CF, in Galden® $> 0.1m/s$ Opt. GCF, grounded cooling flange	8 120 516 1000	15 120 516 1000	Watts
Linear Derating		$T_{case} = 25^\circ C$ $T_{flange} = 25^\circ C$ $T_{fin} = 70^\circ C^*$ *measured at base	Standard plastic case Option CF, fins in air $> 4m/s$ Option CF, in Galden® $> 0.1m/s$ Opt. GCF, grounded cooling flange	0.17 2.66 11.46 22.22	0.33 2.66 11.46 22.22	W/K
Operating Temperature Range	$T_O$	Extended temperature range on request		-40...70	$^\circ C$	
Storage Temperature Range	$T_{ST}$			-50...90	$^\circ C$	
Natural Capacitance	$C_N$	Capacitance between switch poles at $V_{O(max)}$	108	54	pF	
Coupling Capacitance	$C_C$	HV side to GND or control side	Standard devices Opt. GCF, grounded cooling flange	9 90	16 96	pF
Diode Reverse Recovery Time	$t_{rrc}$	$I_F = 10 A$ , $T_{case} = 25^\circ C$	MOSFET parasitic diode	500		ns
Diode Forward Voltage Drop	$V_F$	$I_F = 10 A$ , $T_{case} = 25^\circ C$	MOSFET parasitic diode	3	6	VDC
Auxiliary Supply Voltage	$V_{aux}$	$\pm 2\%$ stability recommended, max. tolerance $\pm 5\%$		5.00		VDC
Auxiliary Supply Current	$I_{aux}$	@ $f_{max}$		600		mADC
Control Signal	$V_{tr}$	$> 3VDC$ recommended		2...6		VDC
Fault Signal Output		TTL compatible, short circuit proof, L=Fault		H= 4 V, L= 0.5 V		VDC
Dimensions	LxWxH	Standard plastic case Option FC, flat case Option CF, non-isolated cooling fins, standard size Option GCF, grounded cooling flange		89x64x28 89x64x19 89x64x63 132x100x35		mm <sup>3</sup>
Weight		Standard plastic case Option FC, flat case Option CF, non-isolated cooling fins, standard size Option GCF, grounded cooling flange		250 175 400 960		g

## Ordering Information

<b>HTS 31-12-B</b>	Transistor switch, 3 kVDC, 125 Amps.	<b>Option ISO-40</b>	Galvanic isolation increased to 40 kVDC
<b>HTS 61-12-B</b>	Transistor switch, 6 kVDC, 125 Amps.	<b>Option ISO-80</b>	Galvanic isolation increased to 80 kVDC
<b>Option HFB</b>	High frequency burst	<b>Option PIN-C</b>	Soldering pins instead of pigtail/plug as control connection
<b>Option HFS</b>	High frequency switching	<b>Option FC</b>	Flat plastic case, module height reduced to 19 mm
<b>Option LP</b>	Low pass at control input (delay +50ns)	<b>Option UL-94</b>	Flame-retardant casting resin according to UL94-V0
<b>Option S-TT</b>	Soft transition time for simplified EMC design	<b>Option CF</b>	Non-isolated cooling fins, standard size, 35 mm height
<b>Option PT-HV</b>	Pigtails for HV connection	<b>Option GCF</b>	Grounded cooling flange, direct attachment to heat sink